

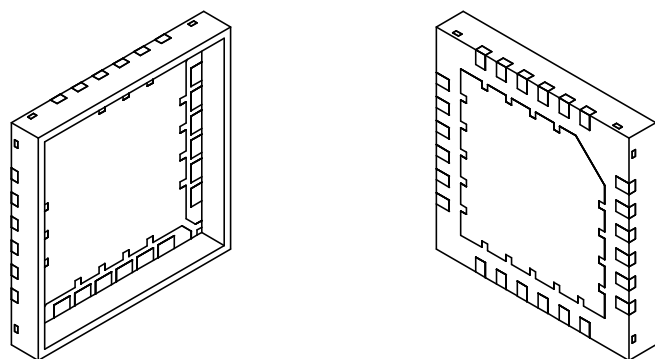

- Notes: (Unless Otherwise Specified)
- 1) BODY; PLASTIC, SEMICONDUCTOR GRADE
 - 2) LEAD FRAME: COPPER, C-194F/H
 - 3) LEAD FRAME PLATING: Ni, Pd, Au
 - 4) FRAME THICKNESS: 0.203mm
 - 5) DIE PAD: 4.5 X 4.5mm
 - 6) JEDEC OUTLINE: MO-220



ISOMETRIC VIEW OF CAVITY SIDE

ISOMETRIC VIEW OF PCB SIDE

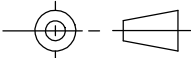
TOLERANCES UNLESS NOTED		APPROVALS		DATE	 www.MirrorSemi.com								
X.X	± 0.05	DRAWN	EDK	03/12/13									
X.XX	± 0.01	CHECKED											
X.XXX	± 0.005	ENG APPR.											
X.XXXX	± 0.0005	MFG APPR.											
ALL DIMENSIONS IN		Q.A.			TITLE: 24-LEAD 6mm P=0.65mm QFN CAVITY PACKAGE								
<input type="checkbox"/> INCHES <input checked="" type="checkbox"/> MILLIMETERS		CUST.											
THIRD ANGLE PROJECTION 		REVISED			<table border="1"> <tr> <td>SCALE</td> <td>SIZE</td> <td>DWG. NO.</td> <td>REV</td> </tr> <tr> <td>10:1</td> <td>A</td> <td>462570 M-QFN24W.65-6MM-G7</td> <td>A</td> </tr> </table>	SCALE	SIZE	DWG. NO.	REV	10:1	A	462570 M-QFN24W.65-6MM-G7	A
SCALE	SIZE	DWG. NO.	REV										
10:1	A	462570 M-QFN24W.65-6MM-G7	A										
DO NOT SCALE DRAWING					SHEET 1 OF 4								

TOP VIEW

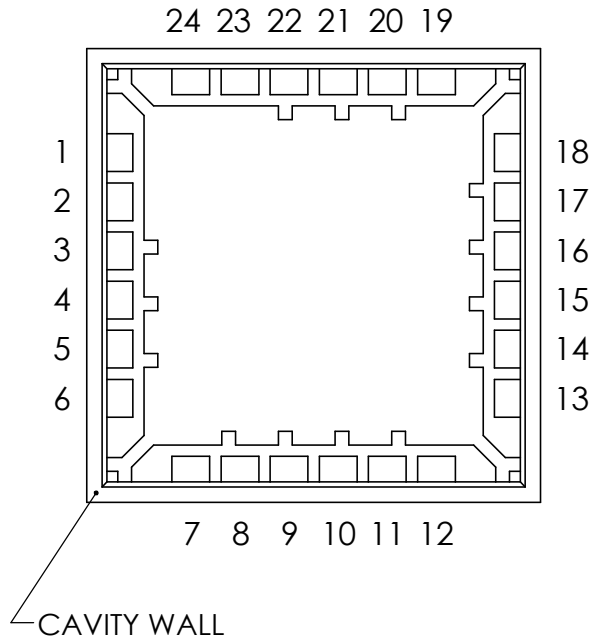

SIDE VIEW
(BEFORE LID ATTACH)

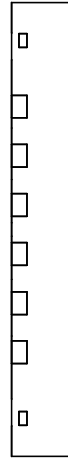

BOTTOM VIEW

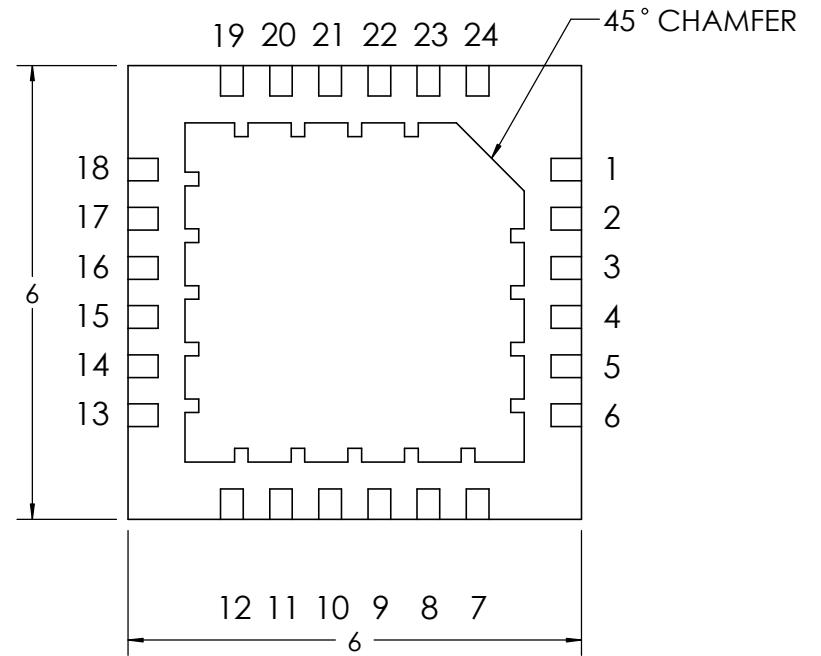

Mirror
Semiconductor™

www.MirrorSemi.com

TITLE:

24-LEAD 6mm P=0.65mm
QFN CAVITY PACKAGE
LEAD NUMBERING

SCALE
10:1

SIZE
A

DWG. NO.
462570
M-QFN24W.65-
6MM-G7

REV
A

DO NOT SCALE DRAWING

SHEET 2 OF 4

BOND DIAGRAM

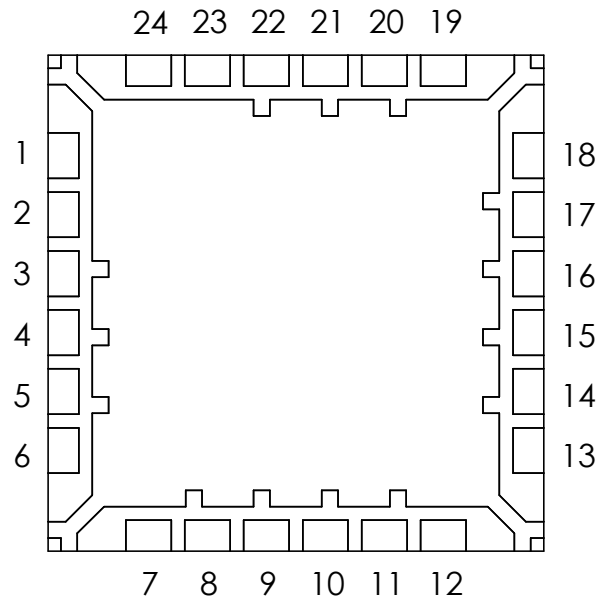

Mirror
Semiconductor™

www.MirrorSemi.com

TITLE:

24-LEAD 6mm P=0.65mm
QFN CAVITY PACKAGE
BOND DIAGRAM

SCALE
12:1

SIZE
A

DWG. NO.
462570
M-QFN24W.65-
6MM-G7

REV
A

DO NOT SCALE DRAWING

SHEET 3 OF 4

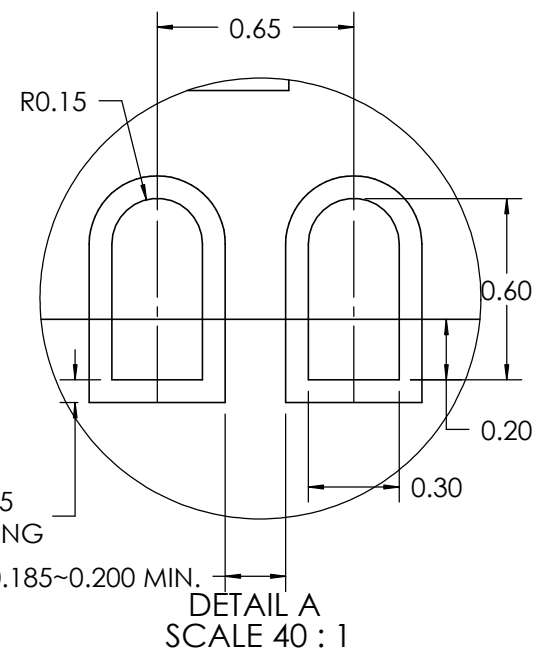
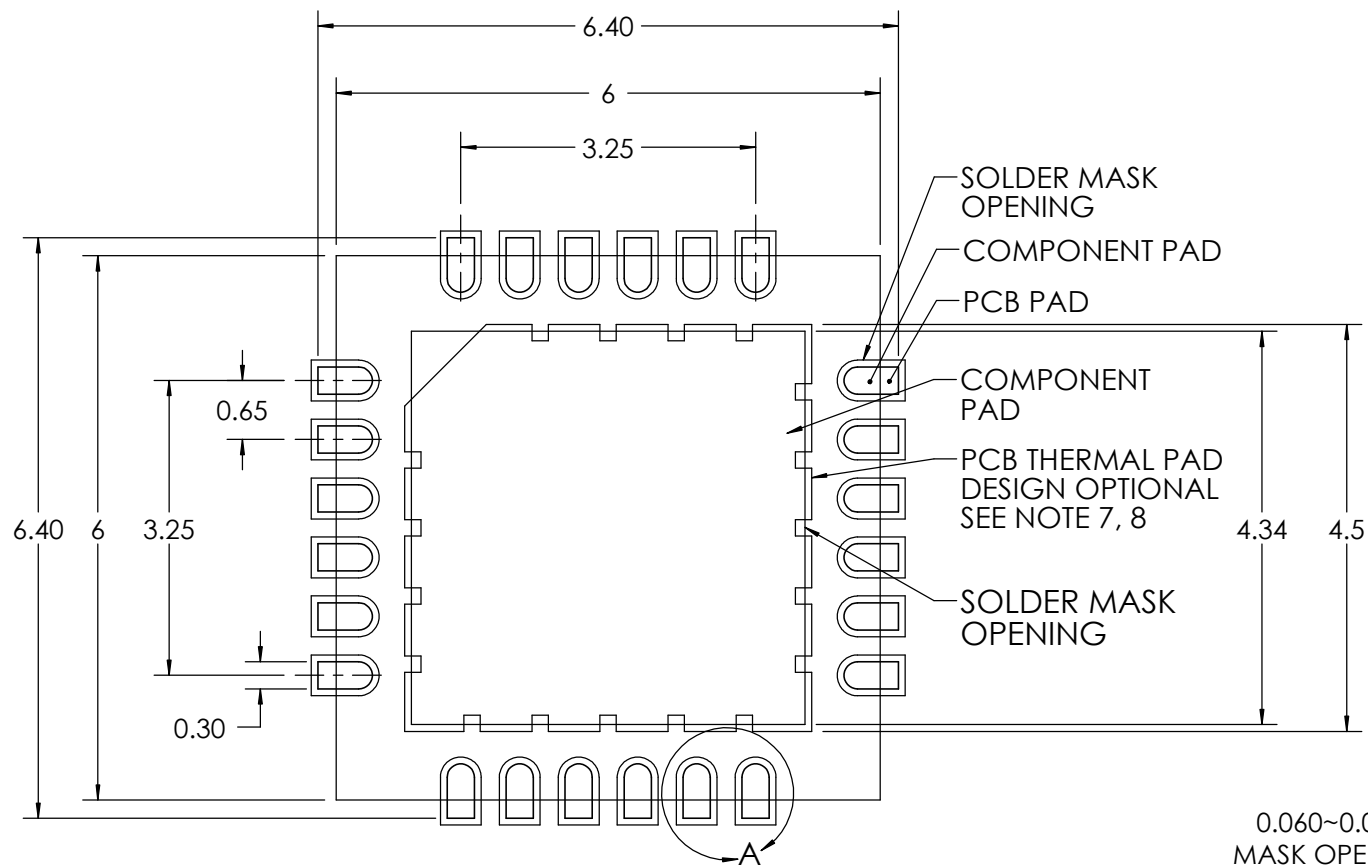

Notes: (Unless Otherwise Specified).

1. DIMENSIONS ARE PRESENTED ONLY AS A GUIDELINE. DESIGNERS SHOULD USE THEIR OWN KNOWLEDGE BASE WHEN DESIGNING THE PCB.
2. SURROUND EACH SIDE OF I/O PERIMETER PADS WITH 0.060~0.075 mm (2.4~3.0mils) NSMD SOLDER MASK OPENING. OPTIONALLY OK TO USE RECTANGLE (NSMD) MASK OPENING AROUND I/O PADS.
3. ROUNDED PCB LAND PADS REDUCE SOLDER BRIDGING. PAD CHAMFER ANGLE MAY VARY.
4. PCB LANDS SHOULD BE 0.2mm LONGER THAN THE PACKAGE I/O PADS.
5. THE WIDTH OF PERIMETER PCB PADS SHOULD MATCH (1:1) THE WIDTH OF THE PACKAGE PADS.
6. REFER TO INDUSTRY REFERENCES SUCH AS IPC-SM-782 FOR PCB LAND PATTERN DESIGN.
7. THERMAL GROUND PADS MAY BE CHANGED TO SUITE REQUIREMENTS OF THE DESIGNER.
 - A. MAKE COPPER THERMAL PAD AS LARGE AS POSSIBLE.
 - B. DRILL MULTIPLE THERMAL VIAS 0.25~0.33mm DIAMETER USING 0.8~1.2mm PITCH GRID.
 - C. PLATE THERMAL VIA BARRELS WITH 1-OUNCE COPPER (18 μ m).
 - D. TENT (COVER) THERMAL VIAS WITH SOLDER MASK 0.1mm LARGER THAN THE VIA DIAMETER.
8. STENCIL DESIGN MAY BE CHANGED TO SUITE REQUIREMENTS OF THE DESIGNER.
 - A. LASER CUT STENCIL 0.125mm (5mil) THICK. APERTURE SIZE-TO-LAND RATIO OF 1:1.
 - B. THE SOLDER PASTE OPENING IN THE THERMAL PAD AREA SHOULD BE A MATRIX ARRAY OF SMALLER APERTURES INSTEAD OF ONE LARGE APERTURE TO CONTROL PASTE AMOUNTS.
 - C. APPLY 50% TO 80% SOLDER PASTE COVERAGE IN THE PAD AREA.

Mirror
Semiconductor™

www.MirrorSemi.com

TITLE: 24-LEAD 6mm P=0.65mm
QFN CAVITY PACKAGE
RECOMMENDED PCB
LAYOUT

SCALE	SIZE	DWG. NO.	REV
12:1	A	462570 M-QFN24W.65- 6MM-G7	A

DO NOT SCALE DRAWING SHEET 4 OF 4