

TOP VIEW

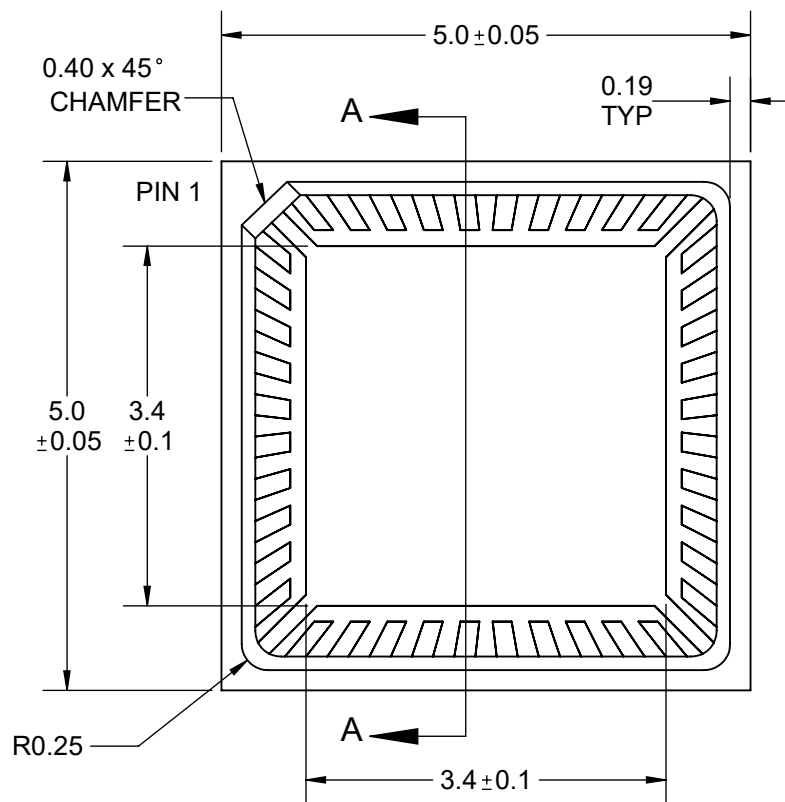

SIDE VIEW

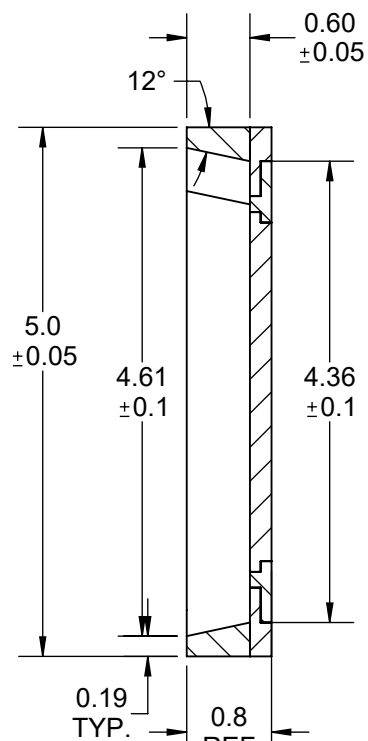

BOTTOM VIEW

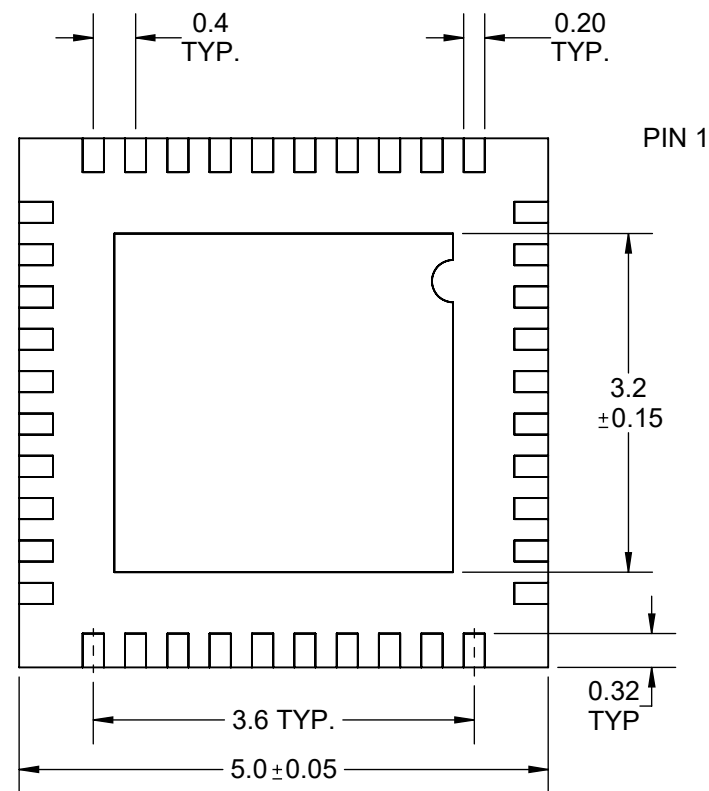

SECTION A-A SCALE 14 : 1

Notes: (Unless Otherwise Specified).

- 1) BODY: PLASTIC, SEMICONDUCTOR GRADE.
- 2) KEAD FRAME: COPPER, C-194 F/H.
- 3) LEAD FRAME PLATING: Ni 2.5~7.6um Au 1.0~2.0um
- 4) FRAM THICKNESS: 0.203MM.
- 5) DIE PAD: 3.4 x 3.4 MM.
- 6) JEDEC OUTLINE: MO-220.
- 7) DIMENSIONS: MM.

APPROVALS	DATE				
DRAWN T.Au	3/18/2020				
ENG M. Hart	3/18/2020	TITLE 40-LEAD 5mm P=0.4 mm M-QFN40T.4-G3			
MFG		SCALE 14:1	SIZE A	DRAWING NO. 444030	REV B
QA					
CUST		DO NOT SCALE DRAWING			SHEET 1 OF 4
REVISED					

PIN LOCATIONS

TOP VIEW

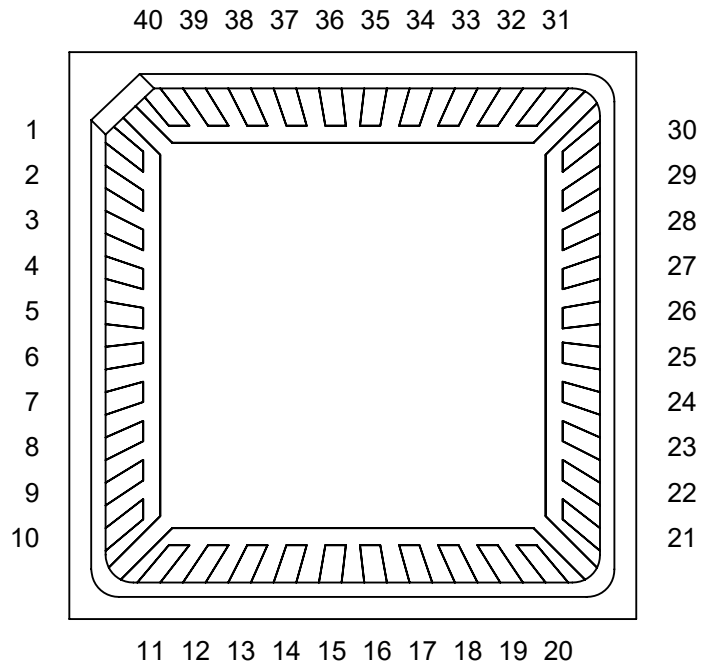

SIDE VIEW (BEFORE LID ATTACH)

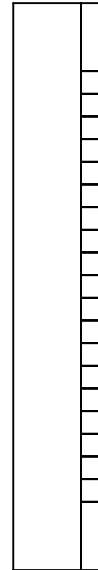

BOTTOM VIEW

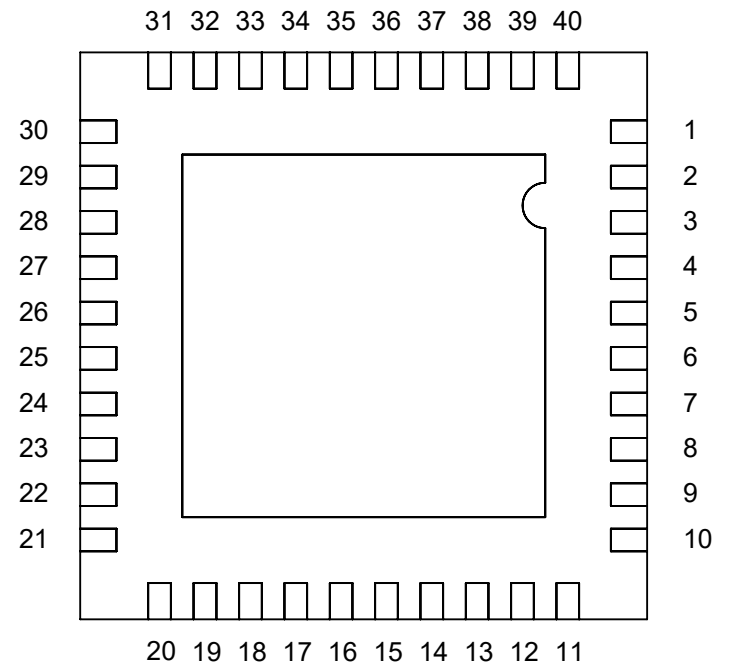

Mirror Semiconductor™			
TITLE		40-LEAD 5mm P=0.4 mm M-QFN40T.4-G3	
SCALE	SIZE	DRAWING NO.	REV
15:1	A	444030	B
DO NOT SCALE DRAWING			SHEET 2 OF 4

BONDING DIAGRAM

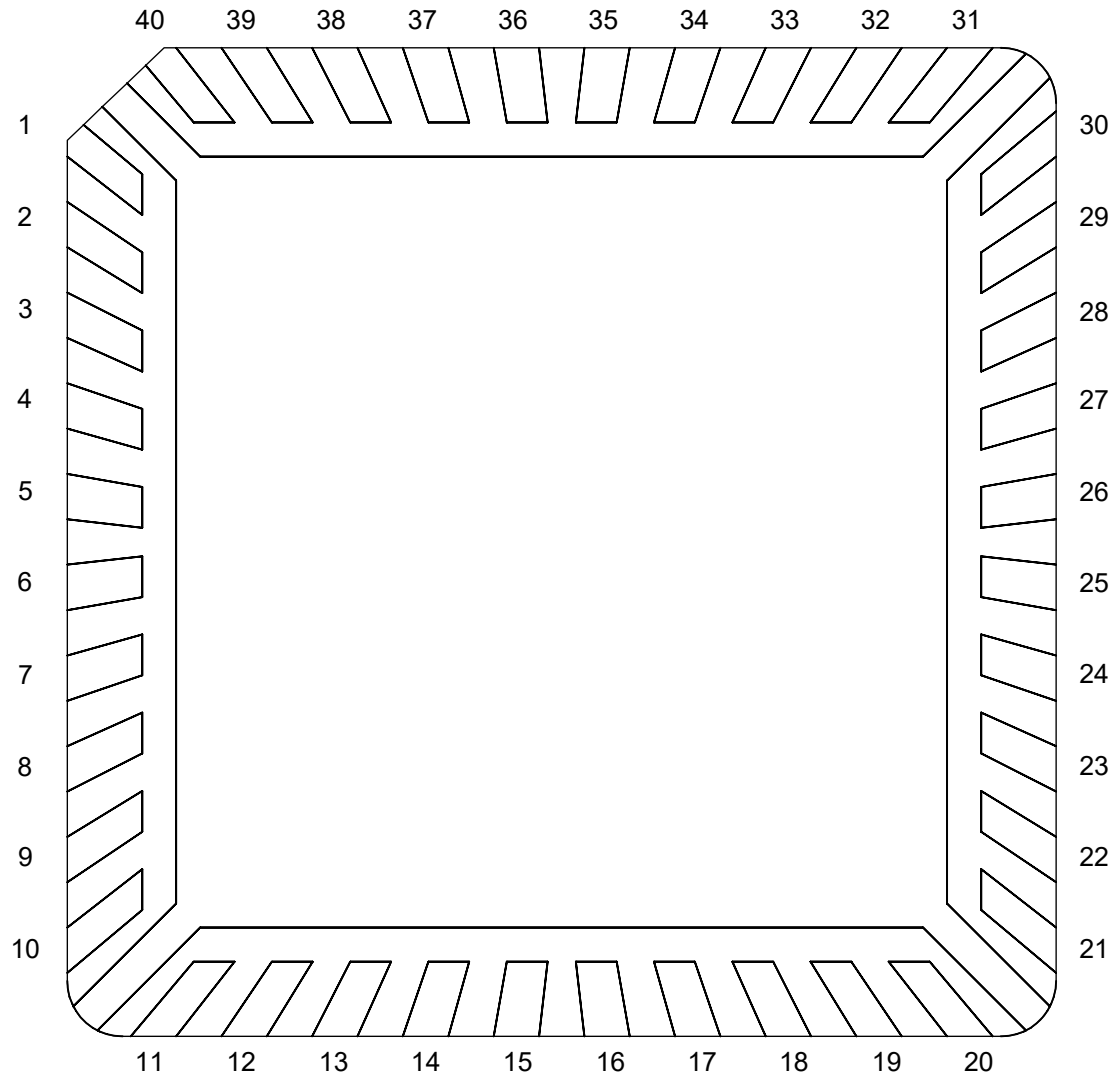

TITLE 40-LEAD 5mm P=0.4 mm
M-QFN40T.4-G3

SCALE 30:1	SIZE A	DRAWING NO. 444030	REV B
---------------	-----------	-----------------------	----------

DO NOT SCALE DRAWING

SHEET 3 OF 4

RECOMMENDED PC BOARD LAYOUT DIMENSIONS IN MM

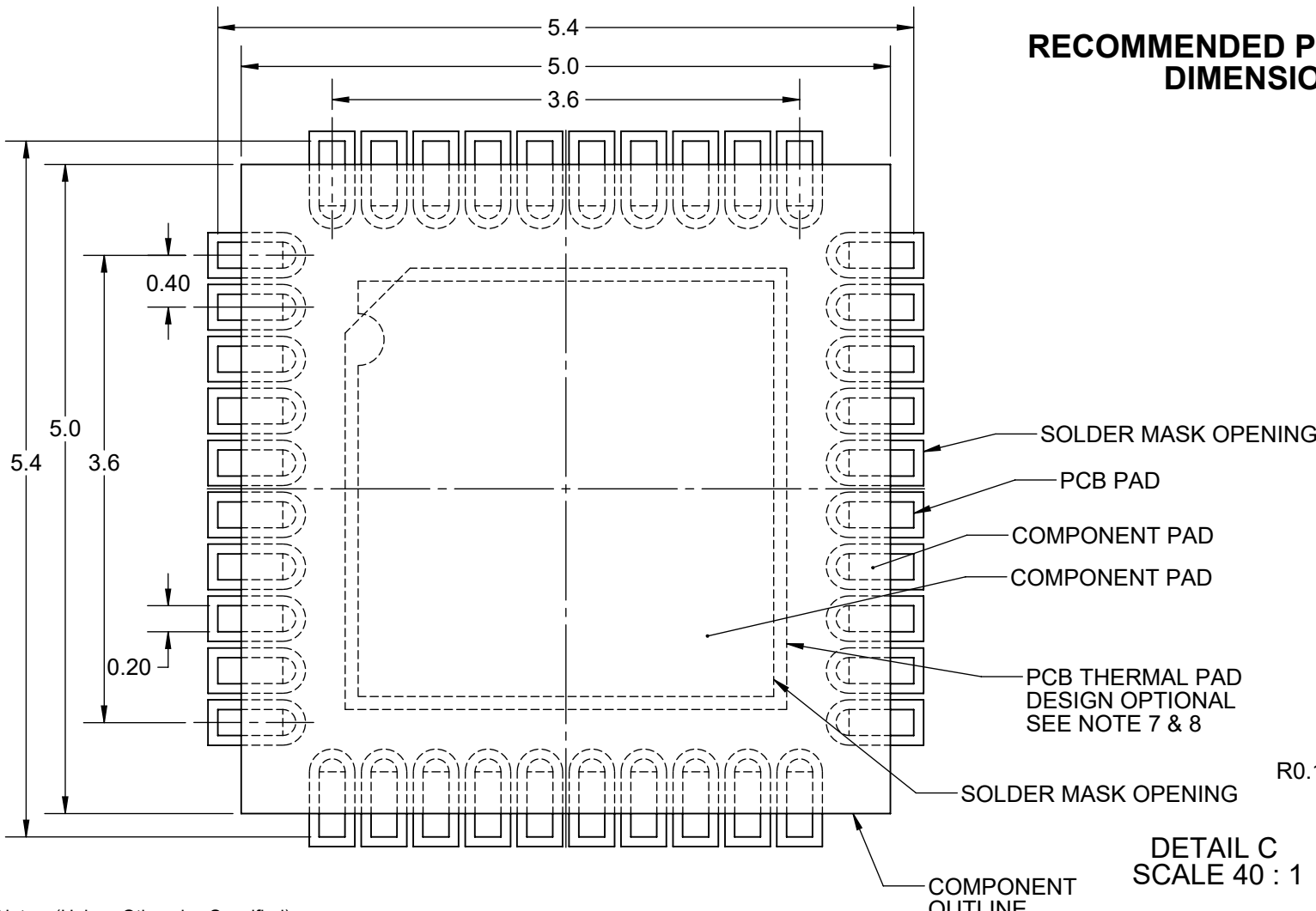

DETAIL C
SCALE 40 : 1

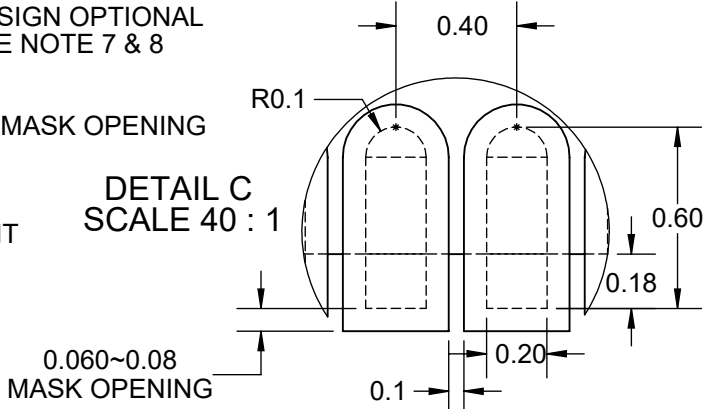

Notes: (Unless Otherwise Specified).

- 1) DIMENSIONS ARE PRESENTED ONLY AS A GUIDELINE. DESIGNERS SHOULD USE THEIR OWN KNOWLEDGE BASE WHEN DESIGNING THE PCB.
- 2) SURROUND EACH SIDE OF I/O PERIMETER PADS WITH 0.060~0.075 mm (NSMD) SOLDER MASK OPENING (2.4~3.0mils). OPTIONALLY OK TO USE RECTANGLE (NSMD) MASK OPENING AROUND I/O PADS.
- 3) ROUNDED PCB LAND PADS REDUCE SOLDER BRIDGING.
- 4) PCB LANDS SHOULD BE 0.2mm LONGER THAN THE PACKAGE I/O PADS.
- 5) THE WIDTH OF PERIMETER PCB PADS SHOULD MATCH (1:1) THE SAME WIDTH AS THE PACKAGE PADS.
- 6) REFER TO INDUSTRY REFERENCES SUCH AS IPC-SM-782 FOR PCB LAND PATTERN DESIGN.
- 7) THERMAL GROUND PADS MAY BE CHANGED TO SUITE REQUIREMENTS OF THE DESIGNER.
 - A. MAKE COPPER THERMAL PAD AS LARGE AS POSSIBLE.
 - B. DRILL MULTIPLE THERMAL VIAS 0.25~0.33mm DIAMETER USING 0.8~1.2mm PITCH GRID.
 - C. PLATE THERMAL VIA BARRELS WITH 1-OUNCE COPPER (18um).
 - D. TENT (COVER) THERMAL VIAS WITH SOLDER MASK 0.1mm LARGER THAN THE VIA DIAMETER.
- 8) STENCIL DESIGN MAY BE CHANGED TO SUITE REQUIREMENTS OF THE DESIGNER.
 - A. LASER CUT STENCIL 0.125mm (5mil) THICK. APERTURE SIZE-TO-LAND RATIO OF 1:1.
 - B. THE SOLDER PASTE OPENING IN THE THERMAL PAD AREA SHOULD BE A MATRIX ARRAY OF SMALLER APERTURES INSTEAD OF ONE LARGE APERTURE TO CONTROL PASTE AMOUNTS.
 - C. APPLY 50% TO 80% SOLDER PASTE COVERAGE IN THERMAL PAD AREA.

Mirror Semiconductor™			
TITLE 40-LEAD 5mm P=0.4 mm M-QFN40T.4-G3			
SCALE 20:1	SIZE A	DRAWING NO. 444030	REV B
DO NOT SCALE DRAWING			SHEET 4 OF 4