

**TOP VIEW**

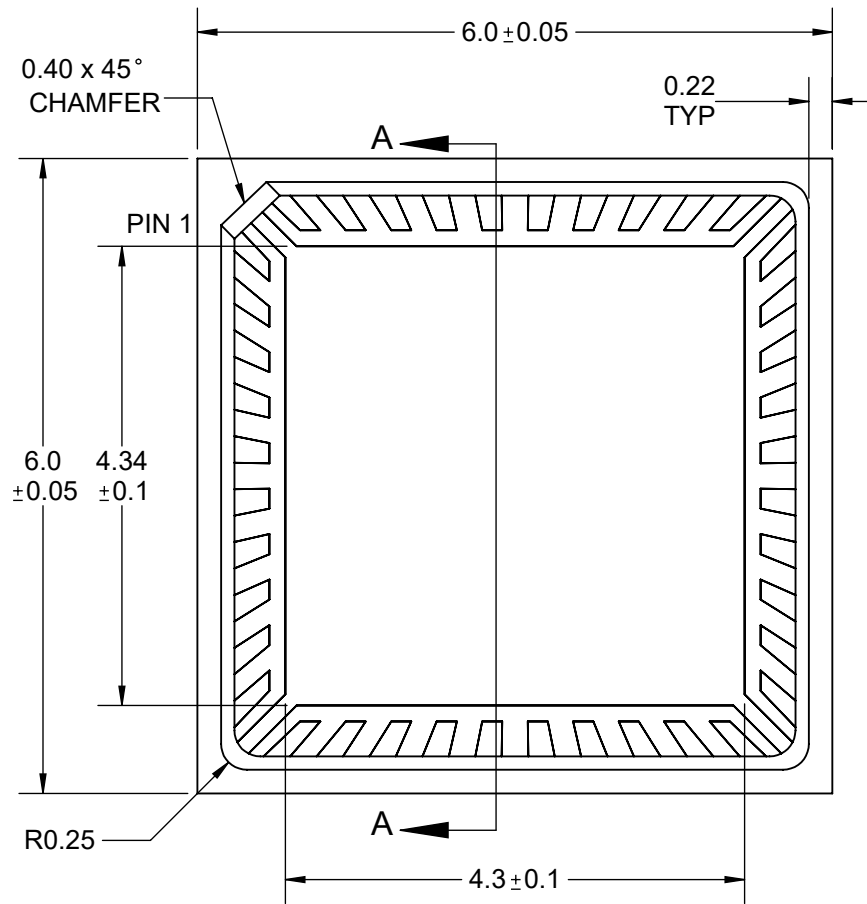

**SIDE VIEW**

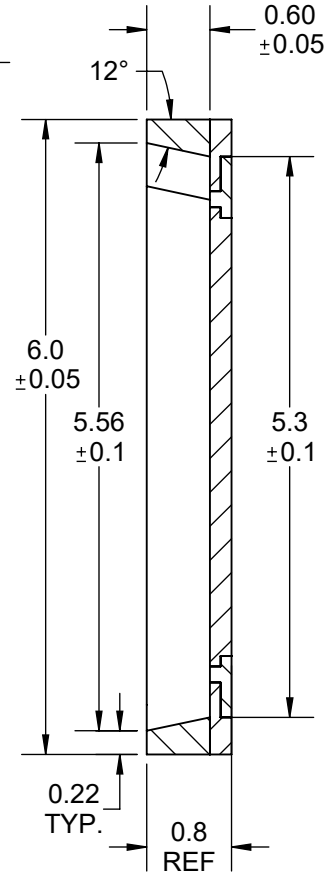

**SECTION A-A  
SCALE 14 : 1**

**BOTTOM VIEW**

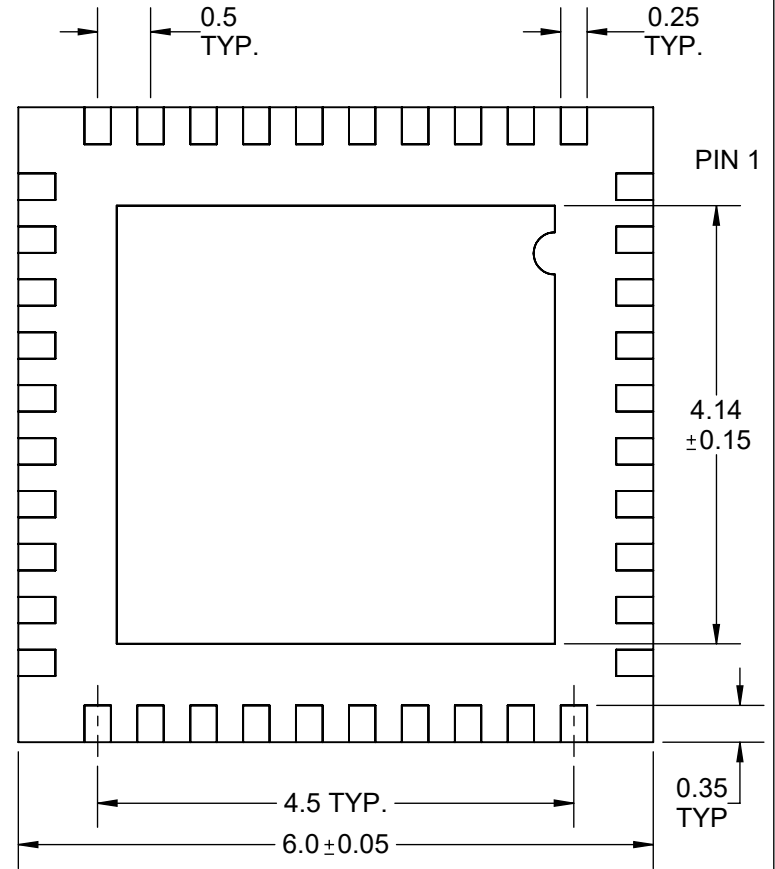

Notes: (Unless Otherwise Specified).

- 1) BODY: PLASTIC, SEMICONDUCTOR GRADE.
- 2) KEAD FRAME: COPPER, C-194 F/H.
- 3) LEAD FRAME PLATING: Ni 2.5~7.6um Au 1.0~2.0um
- 4) FRAM THICKNESS: 0.203MM.
- 5) DIE PAD: 4.34 x 4.34 MM.
- 6) JEDEC OUTLINE: MO-220.
- 7) DIMENSIONS: MM.

APPROVALS	DATE				
DRAWN T.Au	3/13/2020				
ENG M. Hart	3/13/2020	TITLE 40-LEAD 6mm P=0.5 mm M-QFN40T.5-G3			
MFG		SCALE 14:1	SIZE A	DRAWING NO. 454030	REV B
QA					
CUST		DO NOT SCALE DRAWING			SHEET 1 OF 4
REVISED					

# PIN LOCATIONS

## TOP VIEW

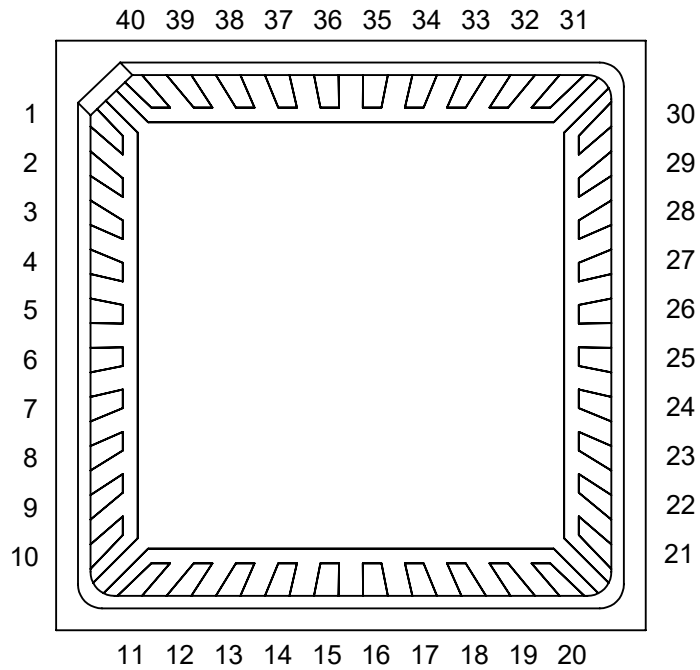

## SIDE VIEW (BEFORE LID ATTACH)

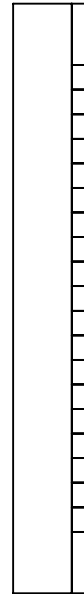

## BOTTOM VIEW

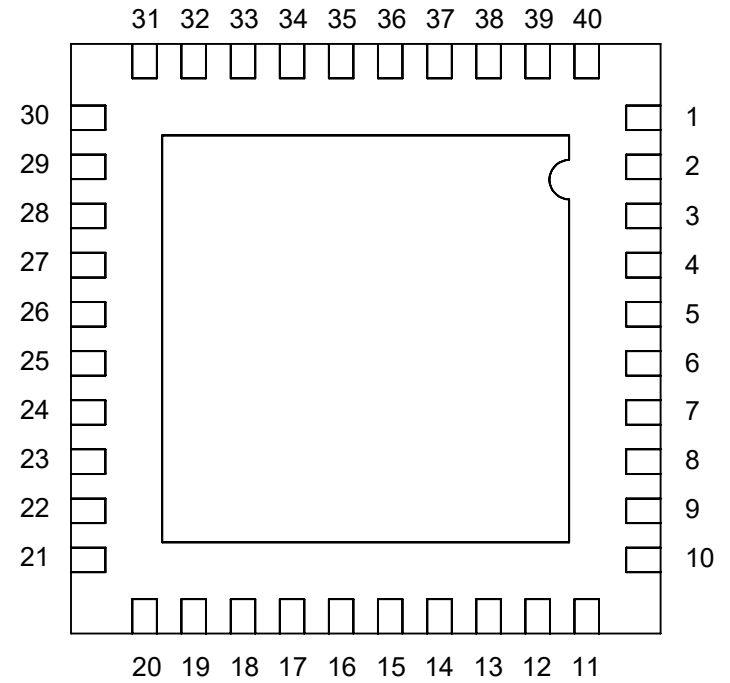

TITLE 40-LEAD 6mm P=0.5 mm  
M-QFN40T.5-G3

SCALE 13:1	SIZE A	DRAWING NO. 454030	REV B
---------------	-----------	-----------------------	----------

DO NOT SCALE DRAWING

SHEET 2 OF 4

# BONDING DIAGRAM

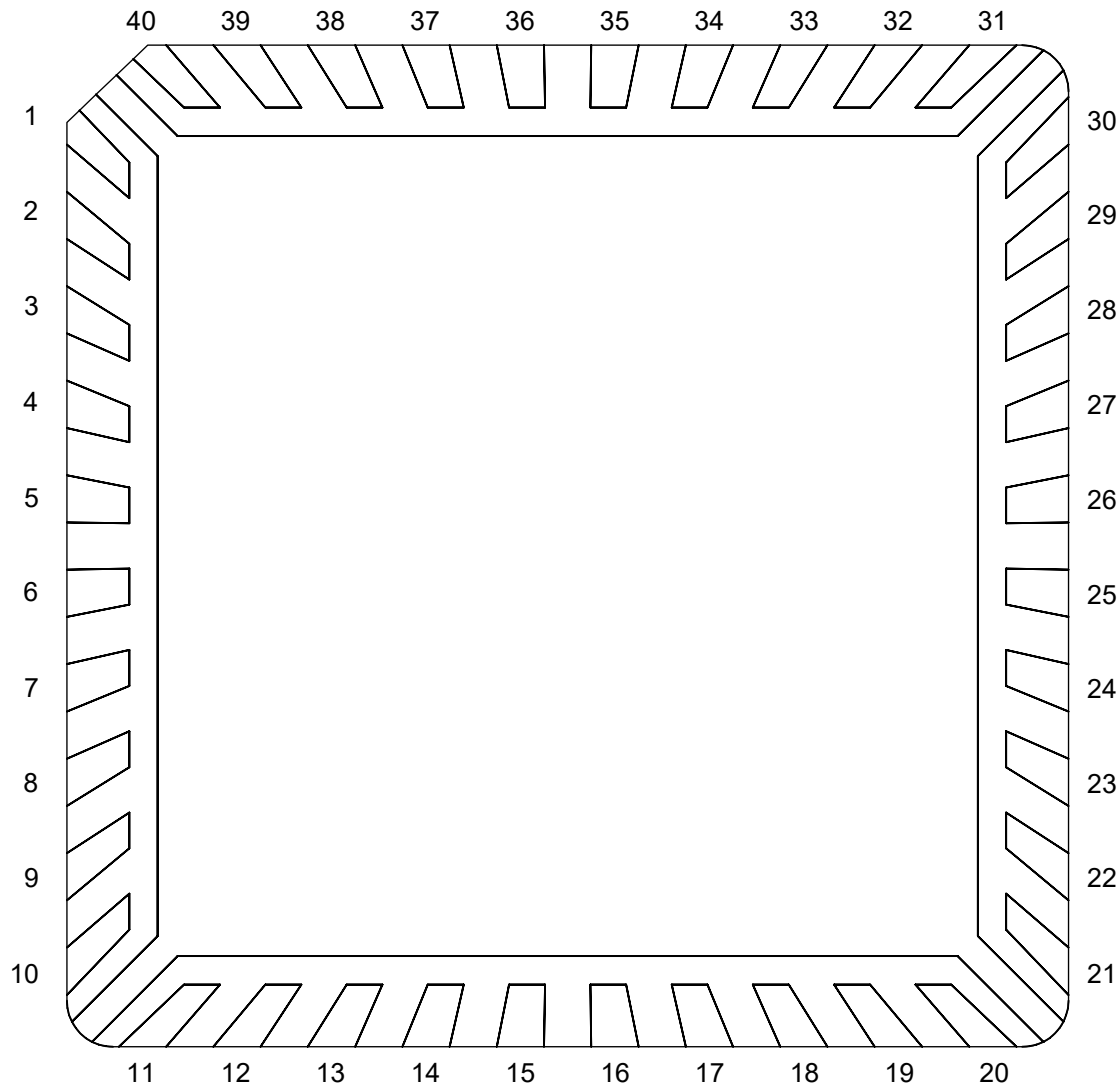

**Mirror**  
Semiconductor™

TITLE 40-LEAD 6mm P=0.5 mm  
M-QFN40T.5-G3

SCALE 25:1	SIZE A	DRAWING NO. 454030	REV B
---------------	-----------	-----------------------	----------

DO NOT SCALE DRAWING

SHEET 3 OF 4

# RECOMMENDED PC BOARD LAYOUT DIMENSIONS IN MM

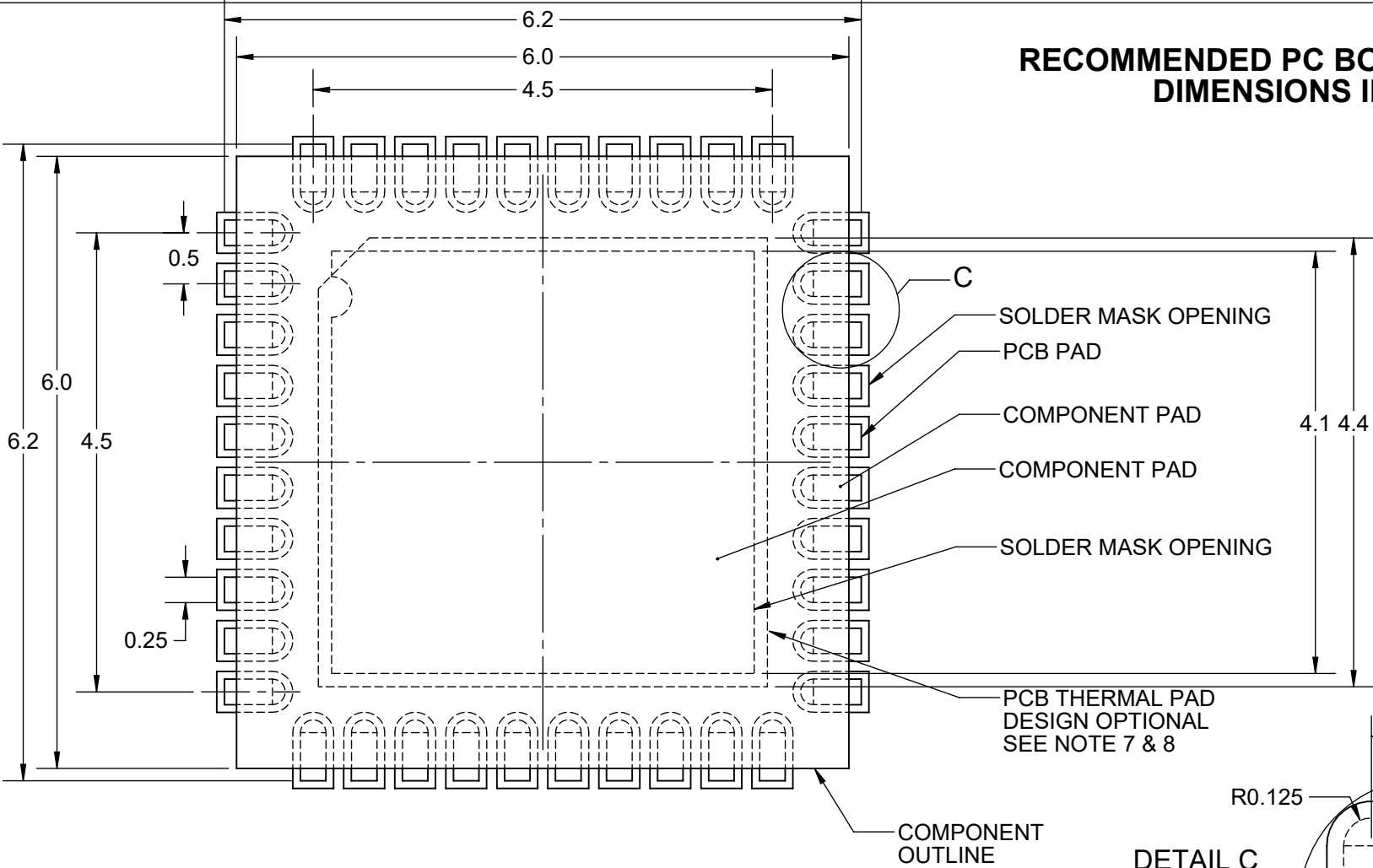

**Notes: (Unless Otherwise Specified).**

- 1) DIMENSIONS ARE PRESENTED ONLY AS A GUIDELINE. DESIGNERS SHOULD USE THEIR OWN KNOWLEDGE BASE WHEN DESIGNING THE PCB.
- 2) SURROUND EACH SIDE OF I/O PERIMETER PADS WITH 0.060~0.075 mm (NSMD) SOLDER MASK OPENING (2.4~3.0mils). OPTIONALLY OK TO USE RECTANGLE (NSMD) MASK OPENING AROUND I/O PADS.
- 3) ROUNDED PCB LAND PADS REDUCE SOLDER BRIDGING.
- 4) PCB LANDS SHOULD BE 0.2mm LONGER THAN THE PACKAGE I/O PADS.
- 5) THE WIDTH OF PERIMETER PCB PADS SHOULD MATCH (1:1) THE SAME WIDTH AS THE PACKAGE PADS.
- 6) REFER TO INDUSTRY REFERENCES SUCH AS IPC-SM-782 FOR PCB LAND PATTERN DESIGN.
- 7) THERMAL GROUND PADS MAY BE CHANGED TO SUITE REQUIREMENTS OF THE DESIGNER.
  - A. MAKE COPPER THERMAL PAD AS LARGE AS POSSIBLE.
  - B. DRILL MULTIPLE THERMAL VIAS 0.25~0.33mm DIAMETER USING 0.8~1.2mm PITCH GRID.
  - C. PLATE THERMAL VIA BARRELS WITH 1-OUNCE COPPER (18um).
  - D. TENT (COVER) THERMAL VIAS WITH SOLDER MASK 0.1mm LARGER THAN THE VIA DIAMETER.
- 8) STENCIL DESIGN MAY BE CHANGED TO SUITE REQUIREMENTS OF THE DESIGNER.
  - A. LASER CUT STENCIL 0.125mm (5mil) THICK. APERTURE SIZE-TO-LAND RATIO OF 1:1.
  - B. THE SOLDER PASTE OPENING IN THE THERMAL PAD AREA SHOULD BE A MATRIX ARRAY OF SMALLER APERTURES INSTEAD OF ONE LARGE APERTURE TO CONTROL PASTE AMOUNTS.
  - C. APPLY 50% TO 80% SOLDER PASTE COVERAGE IN THERMAL PAD AREA.

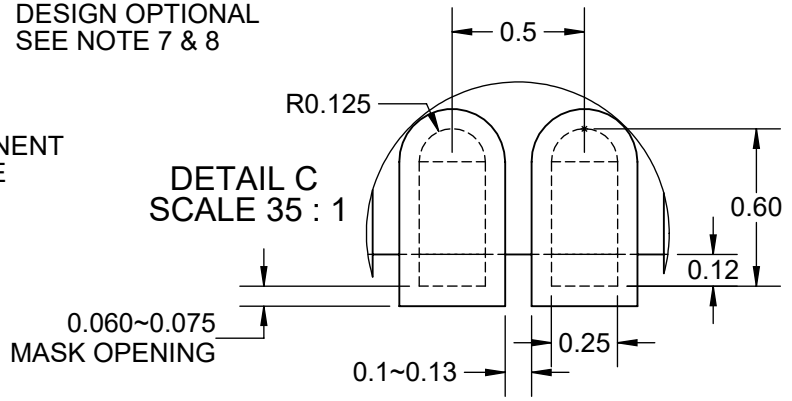

<b>Mirror</b> Semiconductor™			
TITLE 40-LEAD 6mm P=0.5 mm M-QFN40T.5-G3			
SCALE 16:1	SIZE A	DRAWING NO. 454030	REV B
DO NOT SCALE DRAWING		SHEET 4 OF 4	