

SECTION A-A

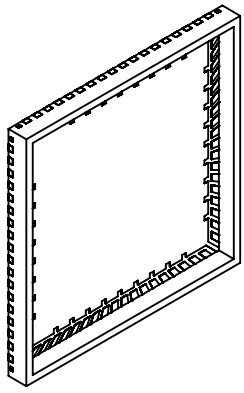

ISOMETRIC VIEW OF CAVITY SIDE

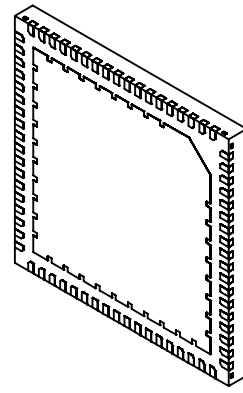

ISOMETRIC VIEW OF PCB SIDE

- Notes: (Unless Otherwise Specified)
- 1) BODY; PLASTIC, SEMICONDUCTOR GRADE
 - 2) LEAD FRAME: COPPER, C-194F/H
 - 3) LEAD FRAME PLATING: Ni, Pd, Au
 - 4) FRAME THICKNESS: 0.203mm
 - 5) DIE PAD: 8.3 X 8.3mm
 - 6) JEDEC OUTLINE: MO-220

| TOLERANCES UNLESS NOTED | | APPROVALS | DATE |
|---------------------------|----------|-----------|------------|
| X.X | ± 0.05 | DRAWN JMG | 03/27/2013 |
| X.XX | ± 0.01 | CHECKED | |
| X.XXX | ± 0.005 | ENG APPR. | |
| X.XXXX | ± 0.0005 | MFG APPR. | |
| ALL DIMENSIONS IN | | Q.A. | |
| □ INCHES ✕ MILLIMETERS | | CUST. | |
| THIRD ANGLE PROJECTION | | REVISED | |

www.MirrorSemi.com

TITLE:

72-LEAD 10mm P=0.50mm QFN CAVITY PACKAGE

| | | | |
|------------|----------|---------------------------------------|----------|
| SCALE | SIZE | DWG. NO. | REV |
| 6:1 | A | 457270 M-QFN72W.5-G7 | A |

DO NOT SCALE DRAWING SHEET 1 OF 4

TOP VIEW

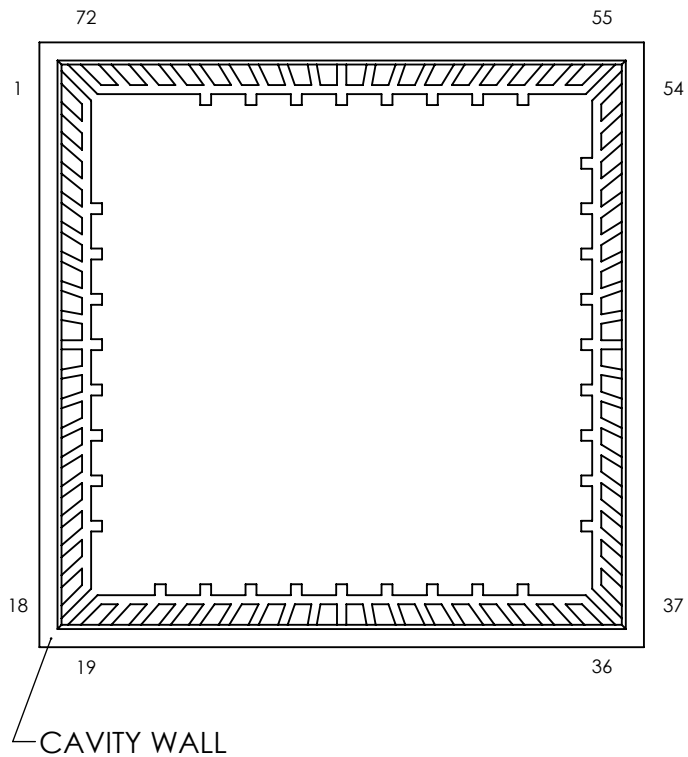

SIDE VIEW
(BEFORE LID ATTACH)

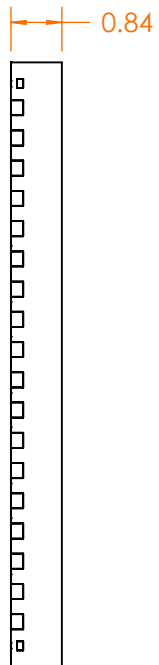

BOTTOM VIEW

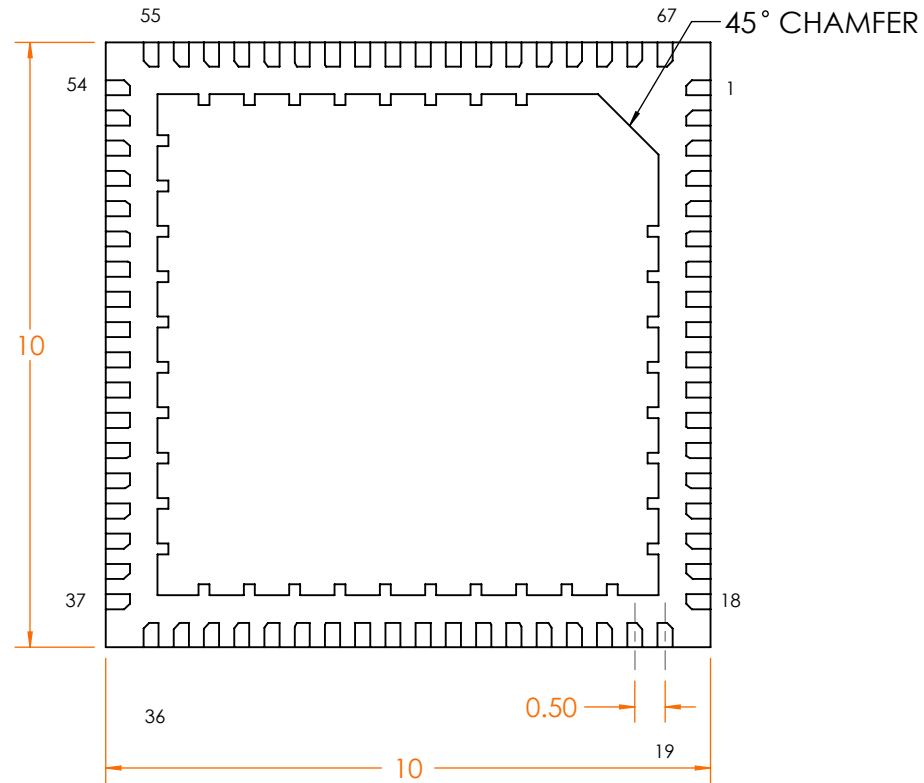

Mirror
Semiconductor™

www.MirrorSemi.com

TITLE:

72-LEAD 10mm P=0.50mm
QFN CAVITY PACKAGE
LEAD NUMBERING

| SCALE | SIZE | DWG. NO. | REV |
|-------|------|-------------------------|-----|
| 8:1 | A | 457270 M-QFN72W.5-G7 | A |

DO NOT SCALE DRAWING

SHEET 2 OF 4

BOND DIAGRAM

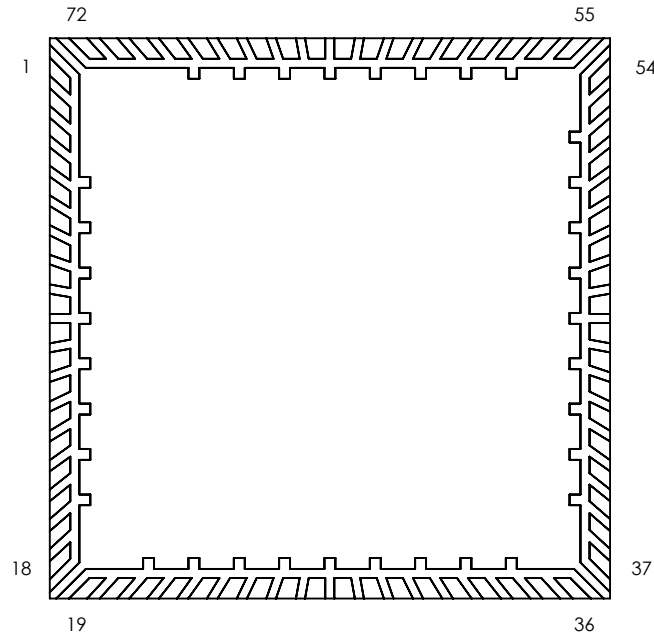

Mirror
Semiconductor™

www.MirrorSemi.com

TITLE:

72-LEAD 10mm P=0.50mm
QFN CAVITY PACKAGE
BOND DIAGRAM

SCALE

8:1

SIZE

A

DWG. NO.

457270
M-QFN72W.5-G7

REV

A

DO NOT SCALE DRAWING

SHEET 3 OF 4

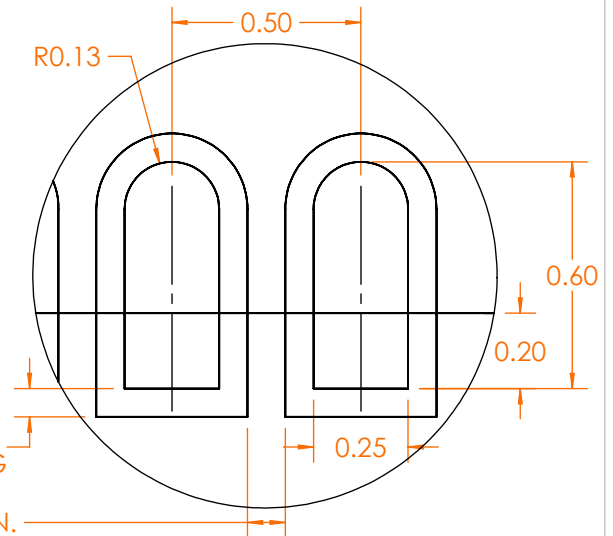
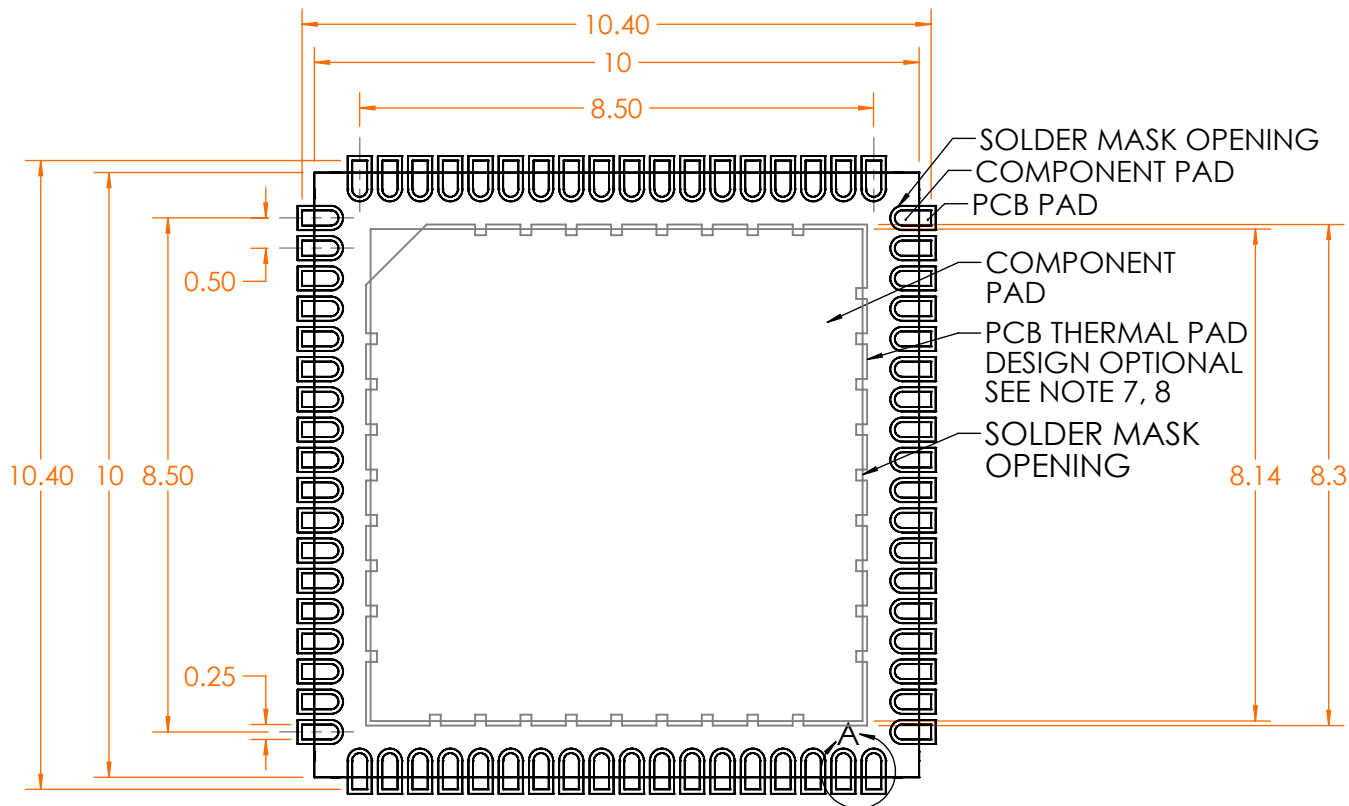

DETAIL A
SCALE 50 : 1

Notes: (Unless Otherwise Specified).

1. DIMENSIONS ARE PRESENTED ONLY AS A GUIDELINE. DESIGNERS SHOULD USE THEIR OWN KNOWLEDGE BASE WHEN DESIGNING THE PCB.
2. SURROUND EACH SIDE OF I/O PERIMETER PADS WITH 0.060~0.075 mm (2.4~3.0mils) NSMD SOLDER MASK OPENING. OPTIONALLY OK TO USE RECTANGLE (NSMD) MASK OPENING AROUND I/O PADS.
3. ROUNDED PCB LAND PADS REDUCE SOLDER BRIDGING. PAD CHAMFER ANGLE MAY VARY.
4. PCB LANDS SHOULD BE 0.2mm LONGER THAN THE PACKAGE I/O PADS.
5. THE WIDTH OF PERIMETER PCB PADS SHOULD MATCH (1:1) THE WIDTH OF THE PACKAGE PADS.
6. REFER TO INDUSTRY REFERENCES SUCH AS IPC-SM-782 FOR PCB LAND PATTERN DESIGN.
7. THERMAL GROUND PADS MAY BE CHANGED TO SUITE REQUIREMENTS OF THE DESIGNER.
 - A. MAKE COPPER THERMAL PAD AS LARGE AS POSSIBLE.
 - B. DRILL MULTIPLE THERMAL VIAS 0.25~0.33mm DIAMETER USING 0.8~1.2mm PITCH GRID.
 - C. PLATE THERMAL VIA BARRELS WITH 1-OUNCE COPPER (18 μ m).
 - D. TENT (COVER) THERMAL VIAS WITH SOLDER MASK 0.1mm LARGER THAN THE VIA DIAMETER.
8. STENCIL DESIGN MAY BE CHANGED TO SUITE REQUIREMENTS OF THE DESIGNER.
 - A. LASER CUT STENCIL 0.125mm (5mil) THICK. APERTURE SIZE-TO-LAND RATIO OF 1:1.
 - B. THE SOLDER PASTE OPENING IN THE THERMAL PAD AREA SHOULD BE A MATRIX ARRAY OF SMALLER APERTURES INSTEAD OF ONE LARGE APERTURE TO CONTROL PASTE AMOUNTS.
 - C. APPLY 50% TO 80% SOLDER PASTE COVERAGE IN THE PAD AREA.

Mirror
Semiconductor™

www.MirrorSemi.com

TITLE: 72-LEAD 10mm P=0.50mm
QFN CAVITY PACKAGE
RECOMMENDED PCB
LAYOUT

| SCALE | SIZE | DWG. NO. | REV |
|-------|------|-------------------------|-----|
| 8:1 | A | 457270 M-QFN72W.5-G7 | A |

DO NOT SCALE DRAWING

SHEET 4 OF 4