

TOP VIEW

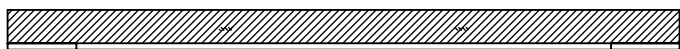

SECTION A-A

SIDE VIEW

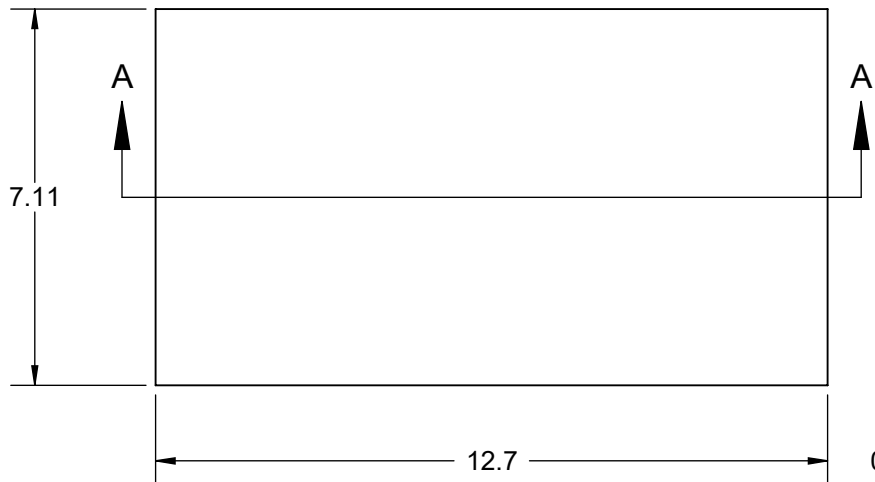
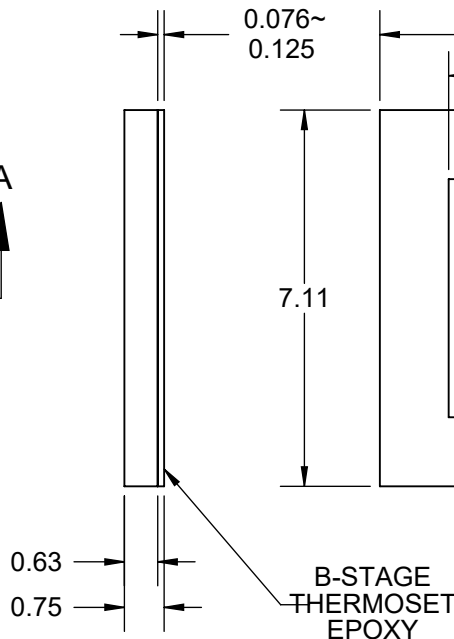

BOTTOM VIEW

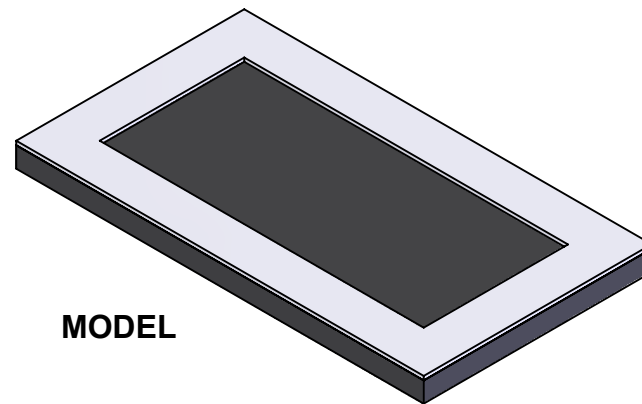
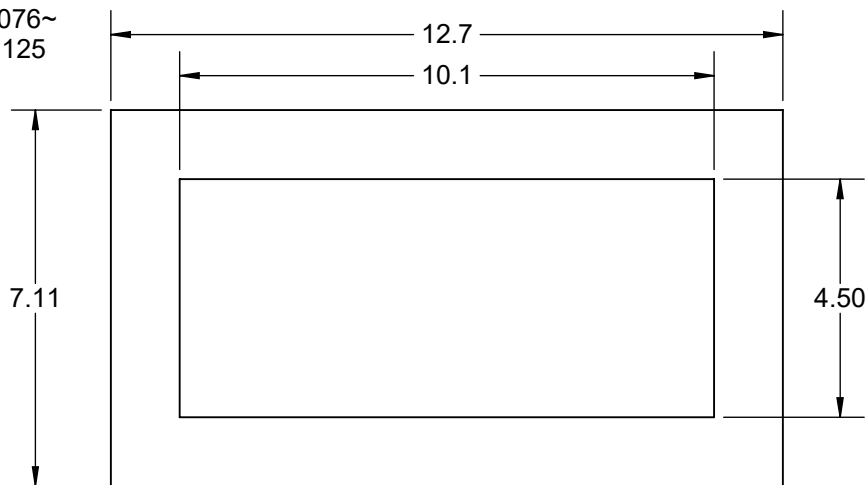

MODEL

NOTES: (Unless Otherwise Specified).

1) MATERIAL:

A) LID: Al_2O_3 BLACK CERAMIC. ALUMINA 91%

B) PREFORM: B-STAGE THERMOSET EPOXY LCA1000X.

2) RECOMENDED CURE: WITH CLAMP PRESSURE 0.035KG/CM SQ.

STEP 1 - PREHEAT PACKAGE @ 75 °C

STEP 2 - CURE AT 125°C FOR 30 MINUTES.

STEP 3 - CURE AT 150°C FOR 60 MINUTES.

3) STORAGE LIFE: 6 MONTHS @ 25°C. 12 MONTHS @ 0°C.

4) DIMENSIONS IN MM.

APPROVALS	DATE	TopLine®			
DRAWN T. Au	4/29/2021				
ENG M. Hart	4/29/2021	TITLE CERAMIC LID FOR SOL28 WITH B-STAGE EPOXY			
MFG		SCALE	SIZE	DRAWING NO.	REV
QA		16:1	A	228073	A
CUST		DO NOT SCALE DRAWING			SHEET 1 OF 1
REVISED					